

GRR-RIPPER®

3D PUSHBLOCK

For use on table saws, bandsaws,
router tables, jointers and more.

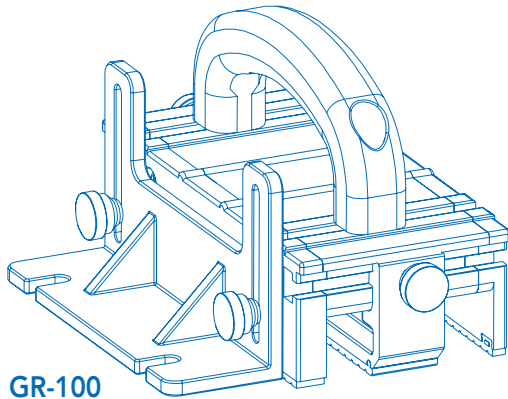

GR-100

GR-100 & GR-200 Instruction Manual v6.0

Read the Important Safety Disclaimers
in this manual prior to use. Keep manual
for future reference.

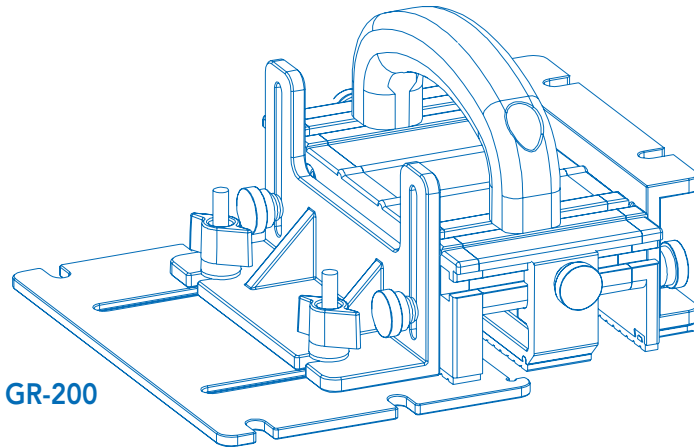

GR-200



THE MICROJIG FAMILY OF BRANDS



GRR-RIPPER®



ZEROPLAY®



MJ SPLITTER™



MICRODIAL™



GRR-RIP BLOCK™

To explore our latest innovations visit us at [MICROJIG.com](https://www.MICROJIG.com)

TABLE OF CONTENTS

Introduction	4-5
Safety Basics	6-8
Assembly	9-11
Techniques:	
Using the 1/4" and 1/2" Leg	14
Irregularly Shaped Stock	15
Balance Support Spacer	15
Resawing	16
Grooving a Round Dowel	16
Bevel Cuts	17
Pattern Routing	17
Slotting	17

NOTE: Please check if you have all the parts and hardware before assembling.

GRR-RIPPER models are available in black or yellow. Part colors may vary depending on model purchased.

If you have purchased the GRR-RIPPER Upgrade Kit (GRAK-404) please reference Step 6 on Page 10 for installation instructions.

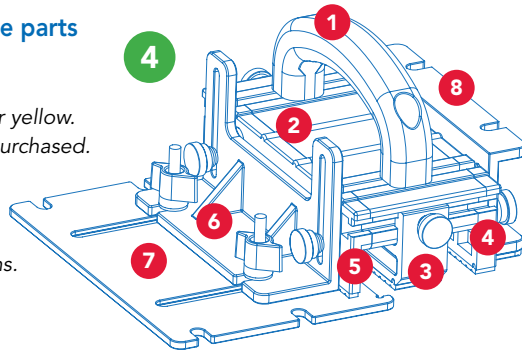

WARNING! The GRR-RIPPER 3D PUSHBLOCK system is capable to control stock narrower or shorter than the GRR-RIPPER on your woodworking machines, user must make sure that the Balance Support and the Adjustable Spacer are properly adjusted to keep the GRR-RIPPER balanced on the stock so it will not tip in any direction, example shown in Fig 16 on page 15.

User must pay attention to the gripping effectiveness of the Green Non-Slip pads before every use, do not use the GRR-RIPPER if you feel it is not gripping the stock, clean with denatured/rubbing alcohol or replace the leg(s) with new Green GRR-RIP® non-slip pads, if necessary.

GRR-RIPPER PARTS

	GR-100	GR-200
1 Handle	1	1
2 Main Body	1	1
3 Center Leg	1	1
4 1/2" Side Leg	1	1
5 1/4" Side Leg	1	1
6 Balance Support	1	1
7 Stabilizing Plate		1
8 Adjustable Spacer		1

HARDWARE

		GR-100	GR-200	Red Bag	Blue Bag
A #10 x 7/16" OD Washer		8	8	8	2
B 1/4 x 1/2" OD Washer		2	2	2	
C 9/32" OD O-Ring (#10 screw) Black		6	6	6	2
D 5/16" OD O-Ring (1/4-20 screw) Orange					2
E 10-32 x 1/2" Thumb Screw		2	2	2	2
F 10-32 x 5/8" Thumb Screw		2	2	2	
G 1/4-20 Oval Nut		2	2	2	
H 10-32 Offset Oval Nut		2	2	2	
K 1/4-20 x 3/4" Pan Head Screw		2	2	2	
L 10-32 x 1/2" Pan Head Screw		4	4	4	
M 1/4-20 x 1 3/4" T-Bolt					2
N 1/4-20 Thumb Knob					2
P Nylon Shoulder Washer					2



NOTE: Parts listing page folds out for your convenience. Reference this page during assembly.

Congratulations on your purchase of the **GRR-RIPPER 3D PUSHBLOCK** system. We have put a lot of thought and effort into designing and making what we believe is the **safest, most precise pushblock available**. Before using your GRR-RIPPER, read through this booklet to familiarize yourself with the GRR-RIPPER and how it works. Here is a general overview of the way the GRR-RIPPER was designed to work:

- The GRR-RIPPER uses grooved non-slip pads (Green GRR-RIP®) to hold down and feed your workpiece through the cutting element. The tool can be rotated end-to-end to for use with either the 1/2" or 1/4" Side Leg against the fence.
- With the rip fence set parallel to the saw blade, the GRR-RIPPER glides against the rip fence to ensure a parallel feed. It also keeps both sides of the workpiece in their original positions throughout the cutting process, which virtually prevents the possibility of kickback and burning. With bare-hand feeding eliminated, finger injury is greatly reduced.
- The GRR-RIPPER feeds the workpiece as the saw blade passes through either its right or left tunnel. This feature provides protection to both hands of the user. The GRR-RIPPER is a protective blade-cover that the user holds regardless of movement.

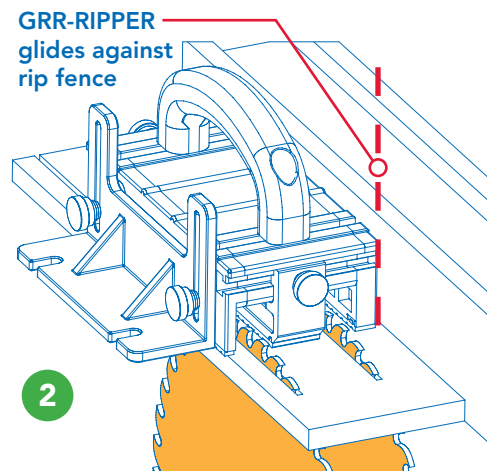
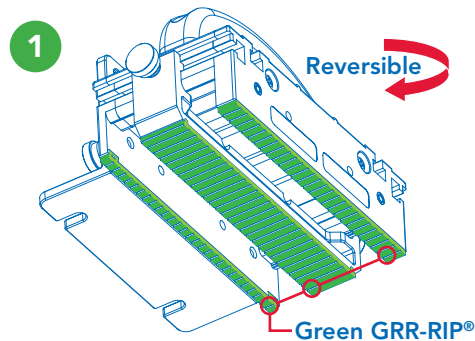

Adjustable design for your project needs.

- A** The Adjustable Handle can be relocated directly above the cut-line, providing balanced and concentrated pressure.
- B** The height adjustable Balance Support accommodates different thicknesses of stock.
- C** The adjustable Center Leg precisely supports different widths of cuts, providing unique control of both sides of stock.
- D** Wooden riser spacers can be added for use with stock thicker than 2". Attach with #8 pan head wood screws and washers (not included).
- E** A wooden spacer can also be added between the GRR-RIPPER and the fence to increase the cutting width capacity of the GRR-RIPPER.
- F** Fully adjustable GRR-RIPPER controls wood of different widths and thicknesses.

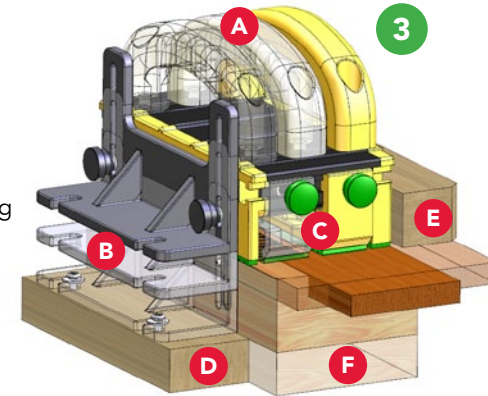

WARRANTY REGISTRATION

Each MICROJIG product includes a one year manufacturer's warranty. Please mail in the provided registration card or complete the registration online at [MICROJIG.com/support/warranty-registration/](https://www.microjig.com/support/warranty-registration/)

RECEIVE THE MICROJIG E-NEWSLETTER

Get our free whitepaper on "4 Easy Ways to Tune-up Your Table Saw" by signing up for the MJ INSIDER. Join the smartest woodworkers worldwide today. Go to [MICROJIG.com/newsletter](https://www.microjig.com/newsletter) and enter your email address. **Work smarter.**

SAFETY WARNING! Operation of the GRR-RIPPER 3D PUSHBLOCK system includes the use of a table saw or other tools that are not part of the GRR-RIPPER. Micro Jig, Inc. assumes no liability for any product not sold and manufactured by Micro Jig, Inc. The user must take all necessary precautions when operating a table saw or other tools as recommended by their manufacturers or as required by any prudent tool user.

You must read and agree to the safety precautions and terms listed below before using the GRR-RIPPER 3D PUSHBLOCK system. Your assembly of the GRR-RIPPER 3D PUSHBLOCK system indicates your agreement to follow these safety precautions and terms when using this tool.

- All components must be inspected for damage and securely fastened before every use. Stop using the tool if any damage occurs.
- In table saw operations, the rip fence must be securely locked parallel to the saw blade within the usable range of the GRR-RIPPER 3D PUSHBLOCK system.
- In table saw operation, the face of the Side Leg on the right must be in full contact with the rip fence at all times in order to create a parallel guide for forward feeding and inward pressure against the rip fence.
- In table saw operations, the GRR-RIPPER 3D PUSHBLOCK system must be used so it is in full contact with the rip fence at all times, and the saw blade MUST pass through and within the tunnel between two of the legs.
- The GRR-RIPPER 3D PUSHBLOCK system includes three legs with non-slip pads. A minimum of two legs MUST be installed during any cutting operation.
- Use at least one leg to the right and one leg to the left of the saw blade whenever possible.
- Before every cut, the user must look through from the end of the tool after it is in an operational position to make sure the cutter will go through the tunnel between the legs throughout

the entire cutting operation, without touching any component of the tool or other objects except the workpiece.

- Use maximum possible coverage of the non-slip pads on the workpiece.
- The GRR-RIPPER 3D PUSHBLOCK system must be used in an absolute stable condition. When a workpiece is narrow and is not covered by the leg on the left (away from fence), the Balance Support must be secured to the left leg so the bottom surface of the Balance Support is in full contact with the table top to secure the steadiness of the tool during the entire cutting operation.
- The non-slip pads placed on the top surface of the workpiece must be in full contact with the workpiece. The user should frequently inspect the effectiveness of the non-slip pads. Remove built up dust as necessary with denatured alcohol.
- The bottom of the workpiece must be flat enough so that it does not rock on the table top. The top of the workpiece must be flat enough so all non-slip surfaces are in full contact with the top surface of the workpiece.
- Do not use this tool if any of the components are damaged. Contact your dealer or the manufacturer for replacement parts.
- When using this tool in conjunction with any other tool, first read and follow all instructions and safety information in the owner's manual for that tool.
- When not in use, store this product on a flat and clean surface.
- Always wear safety glasses and hearing protection. Follow all normal shop safety practices.
- Use saw blades that are designed for the intended cutting operation.
- When using only one GRR-RIPPER, the user must have both hands on this tool - one gripping the handle and the other on top of the main body.
- The machine tabletop used in conjunction with this tool must be flat and free from obstructions other than the required fence and one cutting element. The tabletop must be reasonably level and below the waistline of the user.

- The saw blade must not be set more than 3/4" higher than the top surface of a flat workpiece. The ideal height is when the top gullet is slightly above the top surface of the workpiece.
- It is the sole responsibility of purchaser of this product to ensure that any third party reads and agrees to all safety precautions and terms prior to their use of this tool.
- Do not use this product while under the influence of drugs, alcohol or any medication.
- To clean this product, use denatured (available at the paint department of home improvement centers or rubbing alcohol (available at drug stores).
- When cutting small stock or irregular-shaped workpieces, please ensure the Balance Support and Adjustable Spacer are securely supporting the GRR-RIPPER to prevent any type of tilting. See [Figure 16](#). If the GRR-RIPPER does not appear stable or the user is not confident in making the cut, do not proceed.

IMPORTANT: Never wear loose clothing, gloves, bracelets or other jewelry that may get caught in the moving parts or cutting elements.

TABLE SAW PREPARATION

- You must have a sturdy and straight rip fence with a flat front surface preferably at least 3" in height and square to the table saw top. The rip fence must be long enough to cover the entire depth from the front to the rear of your table saw top. The rip fence must also be equipped with a locking mechanism to secure it on the table saw top so that it is parallel to the saw blade at all scale settings. **DO NOT SKEW THE RIP FENCE!**
- The rip fence should also be accurately calibrated to a fixed scale to secure a precise cutting width setting.
- A sharp and clean carbide-tipped saw blade should be used with this tool for ripping, unless otherwise specified.
- A Zero-Clearance Throat Plate or insert (ZCI) should always be used when cutting narrow strips. Watch our online video on how to install a Zero-Clearance Throat Plate: <http://bit.ly/install-zci>

ASSEMBLY – GRR-RIPPER BASIC MODEL GR-100

Assembly video available online at <http://bit.ly/grr-ripper-assembly>

NOTE: If you purchased a GRR-RIPPER HANDLE BRIDGE KIT (GRHB-010), please refer to its instruction manual for installation and resume GRR-RIPPER assembly at Step 2.

STEP 1

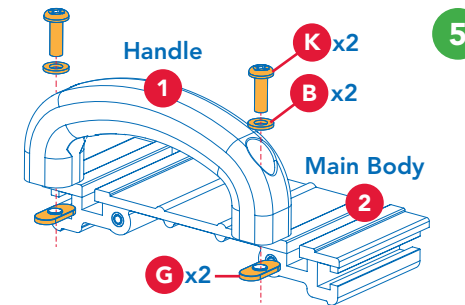

Assemble Handle (1) to the top slots of Main Body (2).

STEP 2

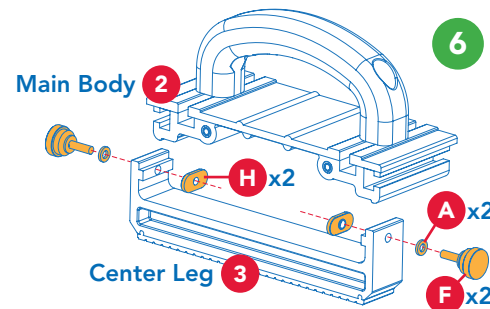

Attach mounting hardware to Center Leg (3). Assemble Center Leg (3) to the end slots of Main Body (2) (see [Figure 6A](#)).

STEP 3 & 4

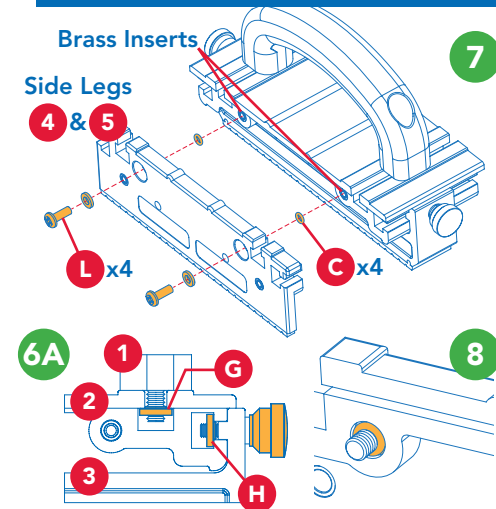

Close-up view with Handle and Center Leg installed on Main Body

Close-up of O-Ring embedded in counter-bore

Install both Side Legs (4) and (5) in the same manner to opposite sides of the Main Body (2). Insert the screws and washers through the front screw holes, insert the O-Rings from the back side. See [Figure 8](#) for detail. **IMPORTANT:** If you purchased the GR-200, do not confuse the Black smaller O-Ring (C) and the Orange larger O-Ring (D).

STEP 5

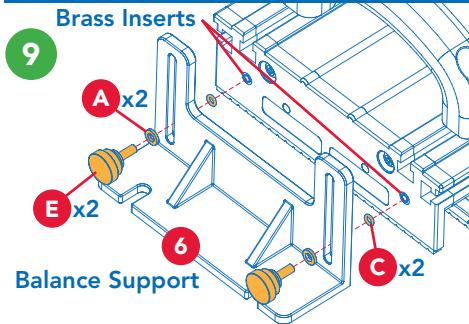

Attach Thumb Screws (E) to Balance Support (6). Assemble Balance Support (6) to either Basic Model GR-100 completed Side Leg (4) or (5).

COMPLETED GR-100

10

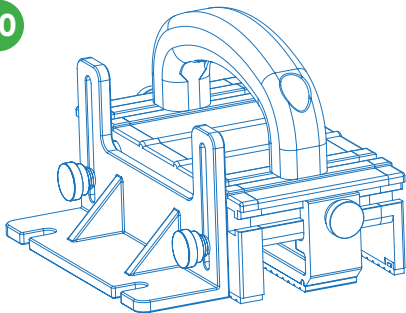

IMPORTANT: To keep the non-slip pads working most effectively, clean the contact surfaces with denatured alcohol or household rubbing alcohol and a shop rag, prior to use. Repeat cleaning during use as necessary when saw dust accumulates. Do not use if Green GRR-RIP is not effectively gripping the workpiece. Please contact MICROJIG in regards to product issues.

ASSEMBLY – GRR-RIPPER ADVANCED MODEL GR-200 (GR-100+GRAK-404)

Assembly video available online at <http://bit.ly/grr-ripper-assembly>

STEP 6

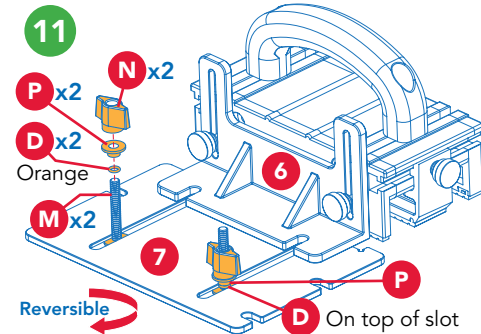

With hardware installed, snap the Stabilizing Plate (7) into the open slots of the Balance Support (6). It is by design that the open slots are narrower than the Shoulder Washer (P), so that the Stabilizing Plate (7) will remain in place during adjustments. The Stabilizing Plate (7) can also be used with its straight edge facing the GRR-RIPPER. **IMPORTANT:** Push the Orange O-Ring (D) through the T-Bolt (M) all the way down, making contact with the Stabilizing Plate (7) before inserting the Shoulder Washer (P) and the Thumb Knob (N).

STEP 7

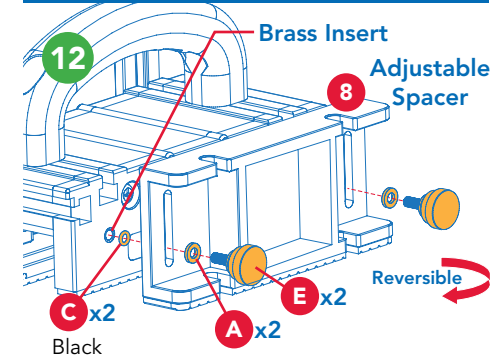

The Adjustable Spacer (8) can be attached to either Side Leg on the right or the left. It can be used with the non-slip pad downward to provide an additional gripping surface pressure. Lower it to achieve two levels of pushing surfaces. It can also perform as a “balancing device” with the non-slip pad facing upward.

COMPLETED GR-200

13

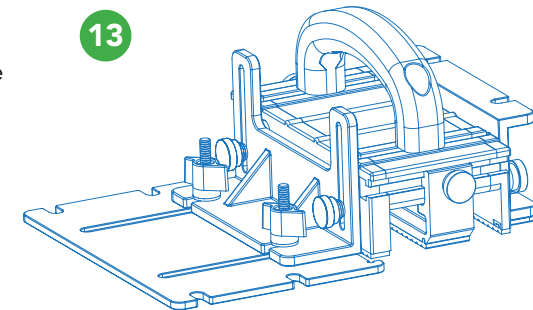

- The GRR-RIPPER 3D PUSHBLOCK system is designed to glide along the rip fence of a table saw, so the rip fence must be **parallel** to the saw blade in order to maintain the parallel feed.
- The saw blade should be raised just enough in height to clear the gullets from the top surface of wood pieces; normally about 1/4" to 3/8". Pay extra caution on workpieces that are not equal in thickness such as tapered stock. The tunnel has a clearance of 15/16" in height.
- The saw blade must pass through the adjustable tunnel and in between the legs for maximum safety. Visually check the Saw Blade Tunnel before turning on your saw to make sure that the saw blade will not cut into any component of the GRR-RIPPER.
- When using a single GRR-RIPPER, both hands should be used on the tool. Place one hand in the inclined position and grip the Handle (1). Place the other on the top of the Main Body (2) to provide added pressure against the rip fence, additional forward feeding and firm downward pressure on the workpiece.
WARNING: NEVER feed stock using bare hands when using the GRR-RIPPER.

- The Handle (1) can be secured at an angle in relation to the Side Legs (see [Figure 17](#)) an automatic pressure will be exerted against the fence when the tool is pushed forward.
- For best cutting results, use one non-stop feed from start to finish - do not pause during the cutting operation. Push the workpiece completely clear of the saw blade, stop the motor, and wait for the saw blade to come to a complete stop before releasing pressure from the workpiece.
- The non-slip pads are molded from a thermal plastic that will slightly compress when downward pressure is applied. When setting the height of the Balance Support (6), it is best to set the non-slip pads over the workpiece, put normal downward pressure from the Handle (1), lower the Balance Support (6) until it fully contacts the table saw top, then secure the Balance Support (6) in that position before releasing pressure from the Handle (1). Double-check the setup by applying downward pressure on the tool with one hand and slightly pulling the workpiece under the tool. If not enough contact pressure is either in the front or rear, adjust the Balance Support (6) accordingly.

- Depending on your table saw model, the GRR-RIPPER system should be placed about 1" to 4" from the trailing end of the workpiece, otherwise, the tool will be off the table saw top at the rear before the workpiece will be clear of the saw blade.
- If workpiece is longer than 16", the use of two GRR-RIPPER systems is recommended for connecting two GRR-RIPPERS or use the "leap-frogging" technique for cutting stock of unlimited length.
- If the width of the cut is between 1/4" to 5/8" on the Inside Cut, use the 1/4" Side Leg (5) on the right against the rip fence. If the width of the cut is less than 1/4", it should be obtained from Outside Cut as shown in [Figure 15](#) on Page 16. One advantage of using the GRR-RIPPER for cutting thin strips over the conventional push block method is the width of your prepared stock on the Inside Cut area is substantially reduced. Yield is greatly increased by saving material, thus reducing costs. Most importantly, the saw blade is always within the tunnel, which provides protection for your fingers.
- For a wider Inside Cut that is beyond the limits of the GRR-RIPPER system, wooden spacers of various widths can be added to the Side Leg against the fence (see [Figure 3](#)). You may drill a couple of counter bored holes (5" center-to-center) for 10-32 pan head screws and secure it to the brass inserts on the Side Legs. Alternately, you can use #8 pan head wood screws from the inside wall of the 1/2" Side Leg (4).

WARNING! Before turning on the saw, always visually check the Saw Blade Tunnel to make sure this is enough clearance for the saw blade to pass through safely.

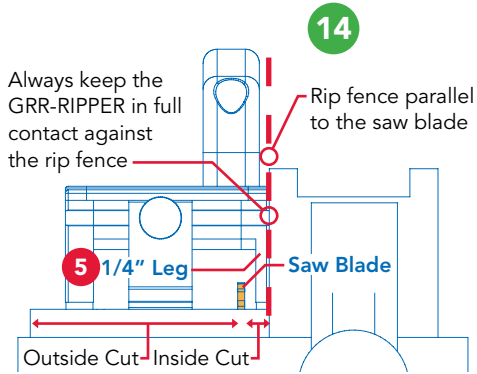

Using the 1/4" Leg

Use the 1/4" Leg (5) against the fence for cutting width (Inside Cut) of 1/4" to 5/8". Note the location of the Handle (1) above the cut line in order to apply balanced pressure to both sides of the stock.

Using the 1/2" Leg

Use the 1/2" Leg (4) against the fence for cutting width (Inside Cut) of 5/8" to 3 3/16". Use the Balance Support (6) when stock is not wide enough to be under the Side Leg on the left. The Handle (1) is secured more towards the right side of saw blade since no pressure is required on the left side of the cut.

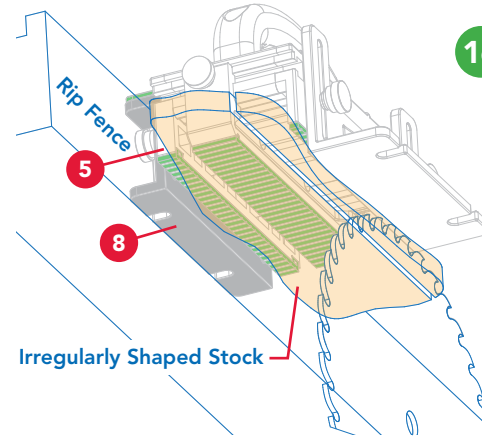
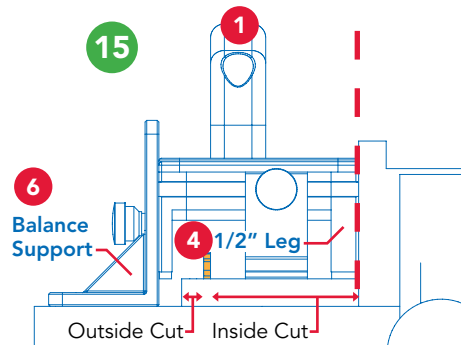

16

Irregularly Shaped Stock

This is a translucent bottom view with the table saw top removed for clarity. The GRR-RIPPER GR-200 is feeding irregularly shaped stock to obtain a straight edge. Notice the 1/2" Leg (5) does not cover the stock edge completely. The Adjustable Spacer (8) is used with the smooth side down and leveled with table top to prevent the tool from tipping over and to glide against the rip fence for a parallel feed. Watch the online video: <http://bit.ly/straight-line-ripping>

Skew Handle (1) to exert "auto" pressure against the fence when pushed.

Balance Support Spacer

Using the Balance Support (6) against the fence will provide an additional 2" of cutting width. The Adjustable Spacer (8) can be used on the left as a balancing device.

Add a wooden spacer for thicker stock - use #8 pan head wood screws & washers (not included).

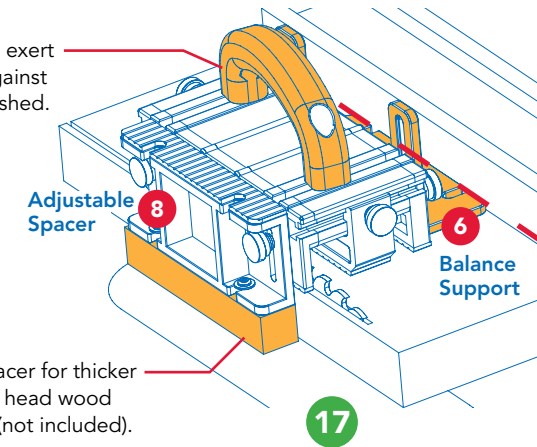

NOTE: All table saw illustrations in this instruction manual show a 1/8" kerf saw blade and a rip fence that is secured parallel and to the right of the saw blade. Inside Cut = Cut between rip fence and the saw blade, is usually the keeper piece. Outside Cut = Cut on the left side of saw blade, is usually the off-cut piece.

Resawing: You can resaw narrow stock in one pass without a band saw, planer or flat-bed sander. **Note:** Stock must be square before resawing.

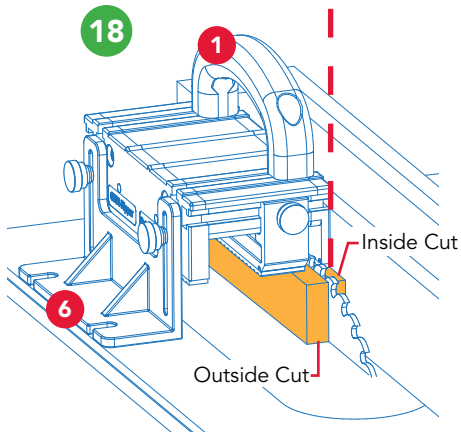

Resawing

Resaw to 1/4" (Inside Cut) or thicker in one pass as shown in Figure 18. Note Handle (1) location.

Resawing stock thinner than 1/4", or resawing wider stock, can be achieved in two passes by setting the saw blade slightly higher than one half of the width of the stock in the first pass. Flip the stock over and finish with a second cut.

Suggestion: Resawing stock thinner than 1/4" should be obtained from the outside cut.

A wooden spacer can be added to the Balance Support (6) for stock wider than 2" (see Figure 3).

Grooving a Round Dowel

With one of the Side Legs removed, the Center Leg (3) is registered against the rip fence, and the Stabilizing Plate (7) of a GR-200 holds the dowel against the rip fence. You can also split a round dowel in half. Watch the online video: <http://bit.ly/split-dowel-safely>

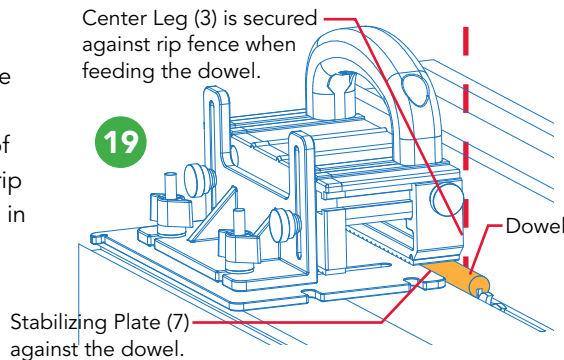

Bevel Cuts

When bevel cutting from 0 to 45 degrees, the GRR-RIPPER provides great control and virtually eliminates binding. Watch the online video: <http://bit.ly/bevel-cut>

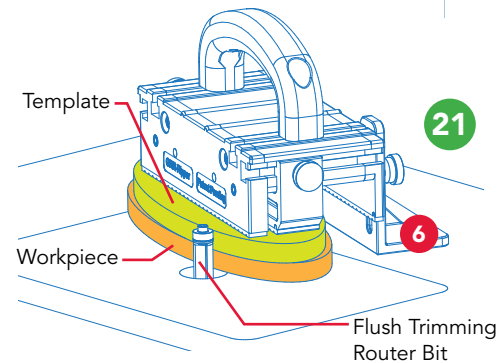
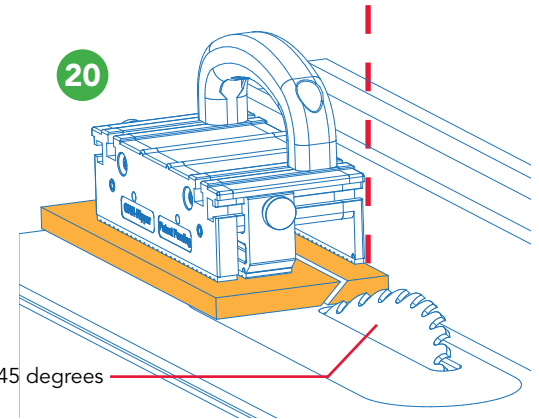

Pattern Routing

Securely holds and guides a small workpiece against a template without tipping over. Use Balance Support (6) to stabilize the GRR-RIPPER when working with narrow or small material.

Slotting

Use the Stabilizing Plate (7) of the GR-200 as a second fence to box-in the workpiece on the router table.

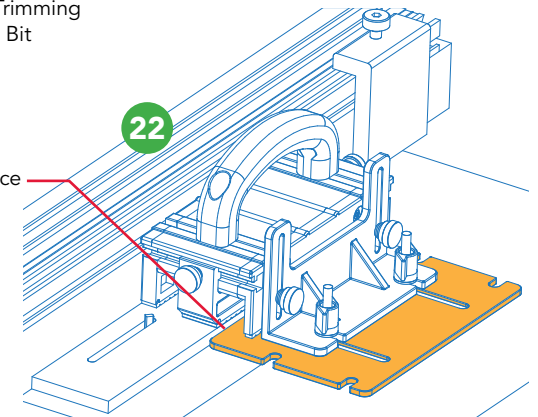

GRR-RIP BLOCK™

SMART HOOK
PUSHBLOCK

NEXT LEVEL PUSHBLOCK

Harness the ultimate gripping power of the only pushblock with smart Gravity Heel hooks that know where to grab your workpiece. Safety's never been so smart. **Work safer. Work smarter.**

- 1 EXTREME GRIP** GRR-RIP BLOCK's cutting edge technology increases safety and stability when working with jointers, band saws, router tables, shapers and table saws.
- 2 VERSATILITY** Use the 90-degree flip guide for veneers or resawing on band saws. Or use GRR-RIP BLOCK against the router fence for beaded face frames and other profiles. The Gravity Heels still engage vertically for superior control.
- 3 PROTECTION** Wield improved control over your workpiece for free hand routing while keeping your hands clear and safe. (GRR-RIP BLOCK shown here with the optional MJ Deflector/Connector accessory.)

Podular Green GRR-RIP® non-slip material gives you command over your work.

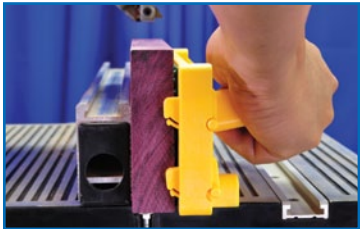

GRR-RIP BLOCK's revolutionary Gravity Heels grab the tail-end of the board or automatically retracts on the board. Easily locks into place when not needed.

MICRODIAL™

TAPERING JIG
For use on table saws with the
GRR-RIPPER ADVANCED MODEL GR-200

CUTTING-EDGE TAPERS

The PRECISION, SAFETY and CONTROL of the **MICRODIAL™ Tapering Jig** advances your woodworking with ease. Combine the MICRODIAL™ Tapering Jig with 1 or 2 GRR-RIPPER ADVANCED GR-200s to craft impeccably tapered legs. Achieve precise angles with the MICRODIAL™ while safely powering through each cut with the GRR-RIPPER.



WORK FASTER Switch quickly and easily between two tapers on a single workpiece. **MEMORYLOCK™** maintains two independent stops for you.

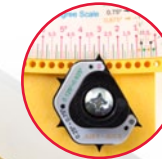

WORK WITH PRECISION The interlocking **COLORMATCH™** system ensures the angle of your taper to 1/8th of a degree (incrementally up to 10 degrees).



VERSATILE TAPERED LEGS

- Create 2-, 4-, 6- or 8-sided tapered legs
- Use on the router table to create custom tapered profiles for exquisite detail on your project legs.

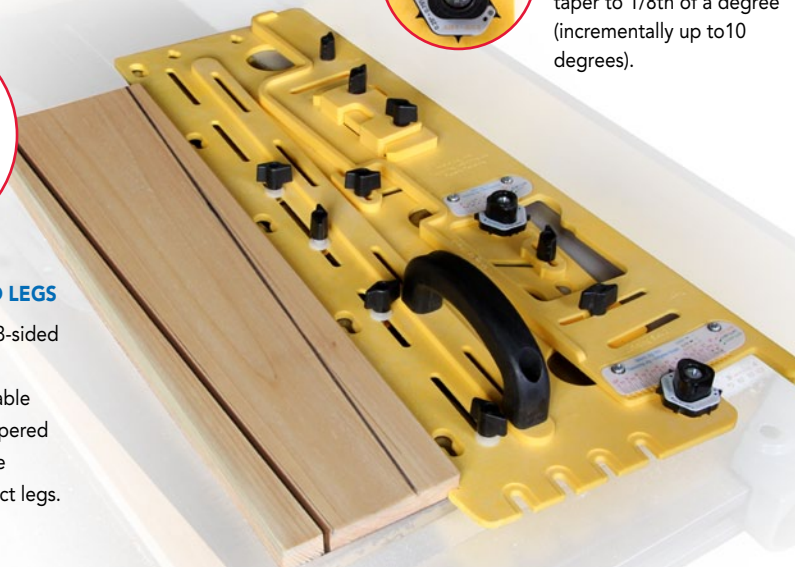



Micro Jig, Inc. • PO Box 195607 • Winter Springs, FL 32719 • USA • MICROJIG.com
MICROJIG, GRR-RIPPER, 3D PUSHBLOCK and Green GRR-RIP are registered trademarks of Micro Jig.
A true Micro Jig innovation. © 2013 US Patent # 7,040,206